

## A-700 Series Cutout — Reverse Current, Rated up to 100 Amps, 28 Vdc

### Product Facts

- SPST NO
- Gasket sealed
- Auxiliary contacts available

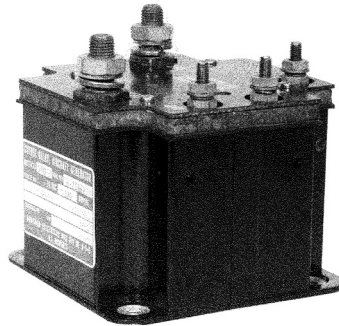

### Performance Data

#### Electrical Characteristics

- Main Contacts** —
- Contact Arrangement** — SPST NO
- Rated Operating Voltage** — 28 Vdc
- Resistive Rating** — 100 Amps
- Resistive Rating at 1 min.** — 200 Amps
- Interrupting Capacity** — 4,500 Amps

- Reverse Current Setting\*** — 2 to 6 Amps
- Differential Voltage for Pickup** —  $.85 \pm .15$  V
- Auxiliary Contacts** —
- Aux. Contact Arrangement** — SPST NC, SPST NO
- Resistive Rating** — 5 Amps
- Inductive Rating** — 2 Amps
- Lamp Rating** — 1 Amps

### General Characteristics

- Weight, Max.** — 3 lbs 1 oz
- Coil Characteristics**
- Duty Cycle** — Continuous

\*Over a Voltage Range of  $27.5 \pm 2.5$  Vdc

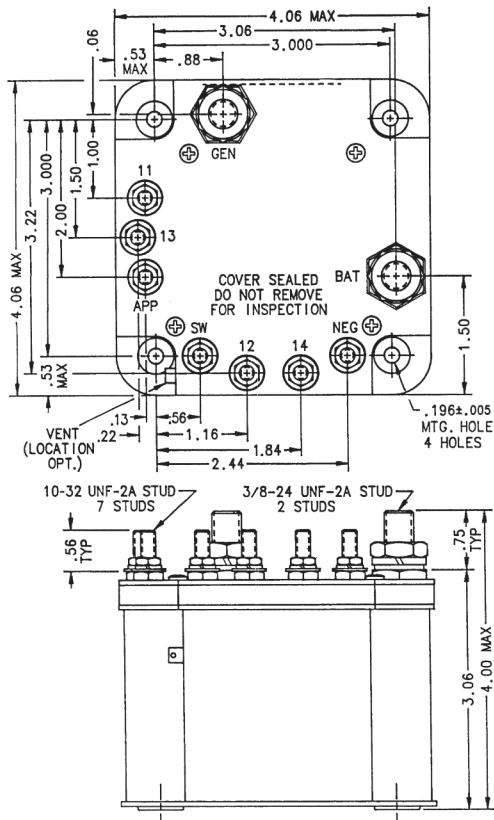

Mounting Style A

### Circuit Configurations (Consult factory for other available circuit configurations)

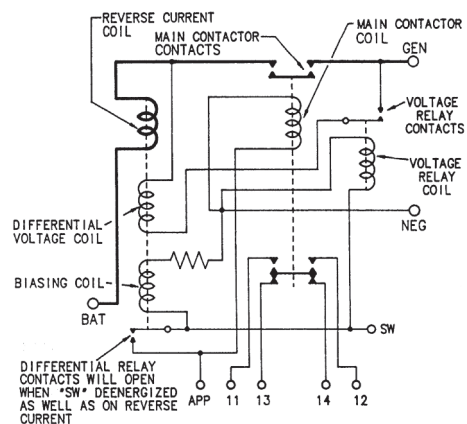

Circuit Configuration 1

For factory-direct application assistance, phone 419-521-9500 or fax 419-526-2749.

HARTMAN Part Number	Construction Type	Mounting Style	Coil Type	Circuit Config.	TE Part Number
A-700BU	Gasket/Vented	A	Continuous	1	1616109-6